

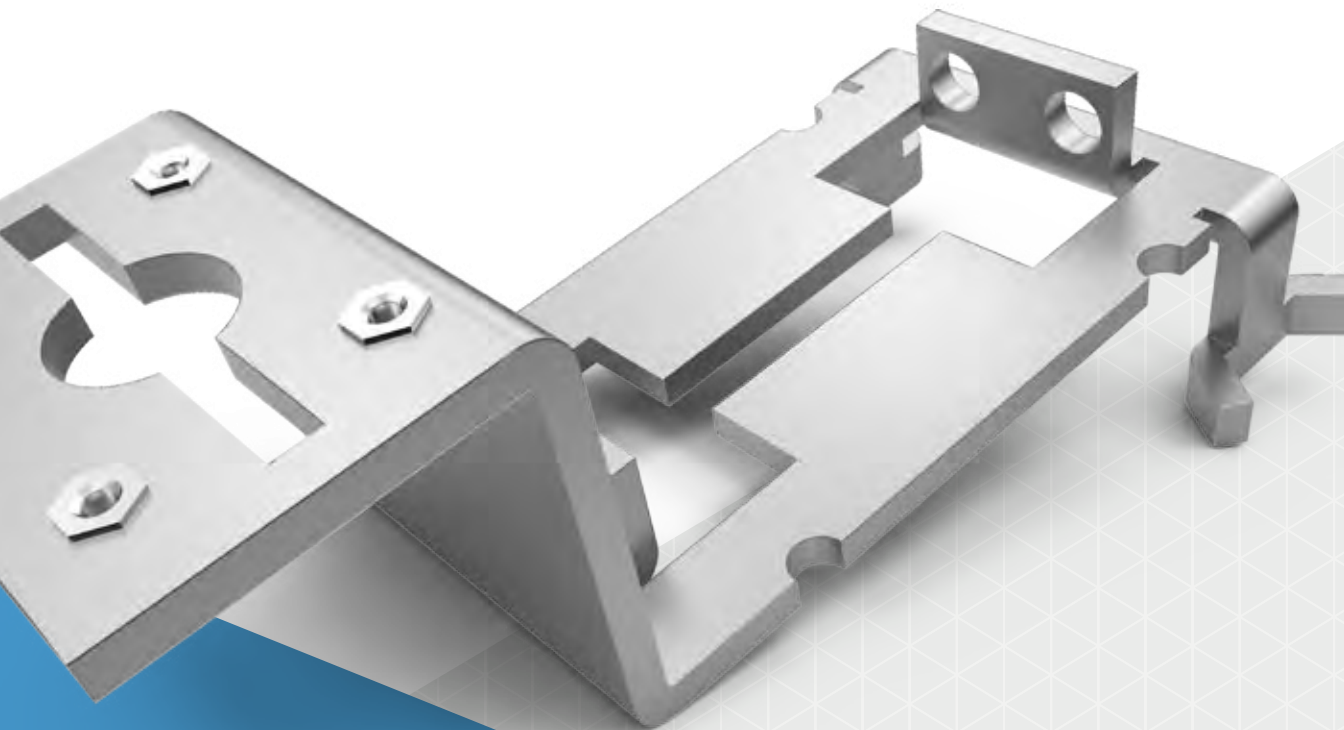

CUSTOM PROTOTYPING AND LOW-VOLUME PRODUCTION IN AS FAST AS 1 DAY

SHEET METAL FABRICATION
CNC MACHINING





We specialize in the accelerated manufacturing of custom prototypes and low-volume production parts with quick-turn sheet metal fabrication and CNC machining services.

REQUEST A QUOTE

Upload a CAD model at rapidmanufacturing.com/quote for a machining or sheet metal quote in less than 24 hours.

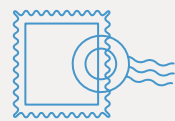

99% On-Time Delivery



99% Quality Rating



myRAPID

Batch upload files for quoting, see past quotes, modify quotes, share access to your account, place orders, and change your contact and shipping information—all in one place at myRAPID.

Create an account at myrapid.rapidmanufacturing.com.



Have eRapid yet? It's a FREE SOLIDWORKS add-in that provides instant sheet metal and machined part costing and design feedback inside your CAD system. Just a few quick steps:

- 1 Download it at erapid.com
- 2 Design your part in SOLIDWORKS
- 3 Run eRapid in SOLIDWORKS
- 4 Get pricing and design feedback in SOLIDWORKS
- 5 Order parts in SOLIDWORKS



WHY RAPID MANUFACTURING?



» SPEED

We know that having parts in your hands on time is critical to your company and product's success, so we pride ourselves on our 99% on-time (or early) shipment of parts.



» HUSTLE

From our quick-turn quoting system to responsiveness to technical questions, we only operate at one speed—we've even been known to chase down the delivery truck to get a package or two on it.



» COMPLEXITY

We have the ability to machine tighter tolerances, larger part sizes with complex features, and special finishes on prototypes and end-use production parts.





SHEET METAL FABRICATION

CUSTOM PROTOTYPING:

1 to 10+ parts
shipped in as fast as 1 day

LOW-VOLUME PRODUCTION:

10 to 1,000+ parts
shipped in as fast as 4 weeks

MAX. PART SIZE:

39 in. x 47 in. (8 ft. length)

COMMON APPLICATIONS:

- Large geometries
- Prototype box builds + end-use components
- Complex assemblies + custom finishes

FINISHING OPTIONS:

- Powder coating (stock colors)
- Chromate
- Anodizing
- Silk screening
- MIG/TIG and spot welding
- Hardware insertion
- Riveting
- Rolling



CNC MACHINING

CUSTOM PROTOTYPING:

1 to 10+ parts
shipped in as fast as 1 day

LOW-VOLUME PRODUCTION:

10 to 1,000+ parts
shipped in as fast as 4 weeks

MAX. PART SIZE:

15.9 in. x 18.9 in. x 2 in. (production);
38 in. x 23.5 in. x 20 in. (prototyping);
12 in. x 8 in. (turning)

COMMON APPLICATIONS:

- 5-axis milling and turning for large and complex parts
- Functional prototypes + commercial-grade components
- Jigs + fixtures

FINISHING OPTIONS:

- Powder coating
- Silk screening
- Plating
- Hardware insertion
- Threading and tapping
- Drilling
- Knurling

MATERIALS

SHEET METAL FABRICATION

- Aluminum
- Cold Rolled Steel (Galvanneal + Galvanized)
- Copper
- Stainless Steel

CNC MACHINING

PLASTIC

- ABS
- Acetal (Delrin)
- Acrylic
- Nylon
- PEEK
- PEI (Ultem)
- Polycarbonate
- Polypropylene
- PTFE
- PVC

METAL

- Aluminum
- Brass
- Copper
- Stainless Steel
- Steel Alloy
- Titanium

ACCEPTED FILE FORMATS

CAD PROGRAMS

- Solidworks (.sldprt)
- Autodesk Inventor (.ipt)
- AutoCAD (3D .dwg)
- PTC ProE/Creo (.prt)
- CATIA (.catpart)

NEUTRAL FORMATS

- IGES (.igs)
- STEP (.stp)
- ACIS (.sat)

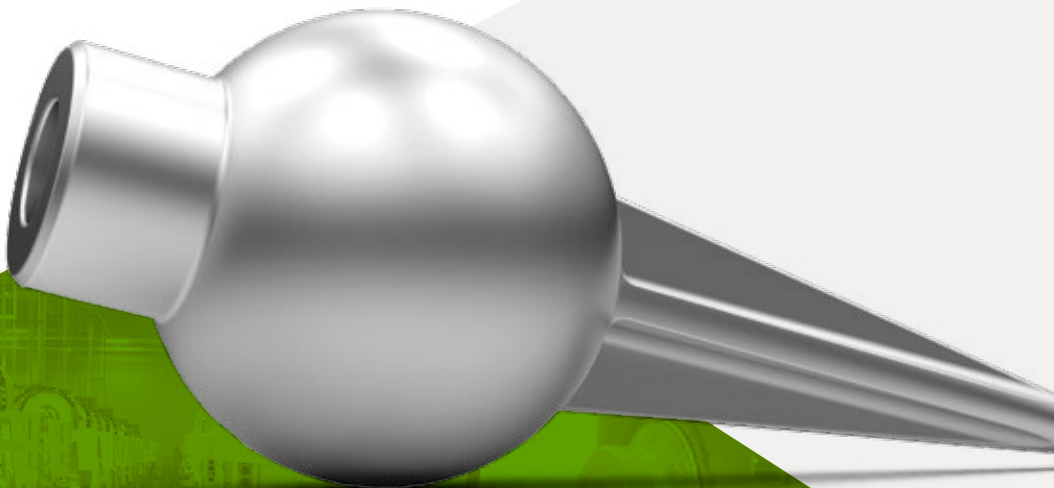



NEED 3D-PRINTED OR MOLDED PARTS FAST?

We recently joined forces with digital manufacturing company Protolabs to provide you with even more options. Its automated quoting system and tech-driven manufacturing processes mean quality parts within days. In addition to CNC machining, have a look at Protolabs' other capabilities:



3D PRINTING

TECHNOLOGY:

- Stereolithography
- PolyJet
- Selective Laser Sintering
- Multi Jet Fusion
- Direct Metal Laser Sintering

CAPABILITIES:

1 to 50+ parts
shipped in as fast as 1 day

COMMON APPLICATIONS:

- Concept models + precision prototypes
- Complex + organic geometries
- Piece reduction in multipart assemblies



INJECTION MOLDING

TECHNOLOGY:

- Plastic Molding
- Liquid Silicone Rubber Molding
- Overmolding
- Insert Molding

CAPABILITIES:

25 to 10,000+ parts
shipped in 15 days or less

COMMON APPLICATIONS:

- Bridge tooling
- Low-volume production
- On-demand manufacturing

Visit [protolabs.com](https://www.protolabs.com) for an online quote with free design analysis within hours.

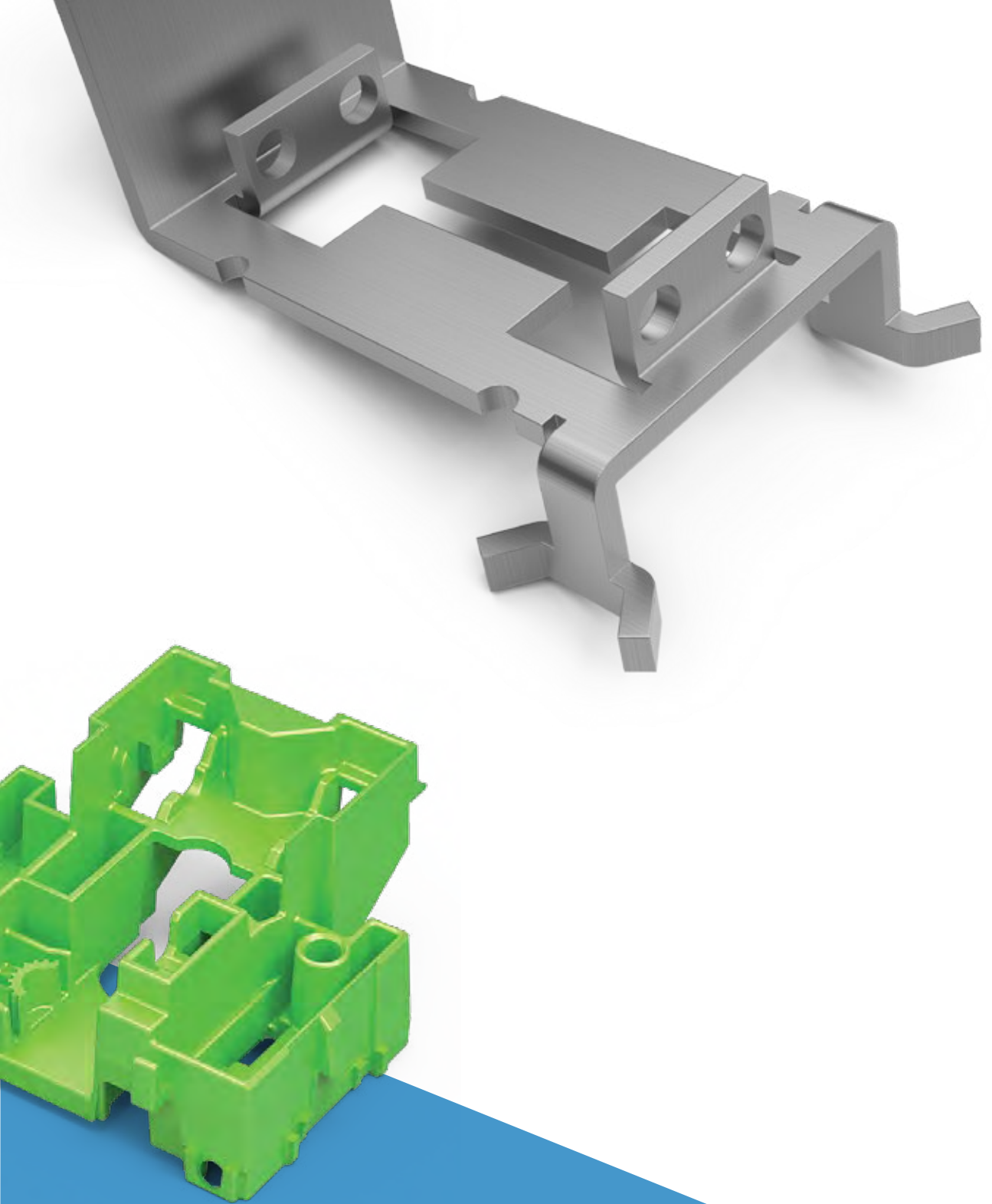

CONTACT US



» rapidmanufacturing.com
603-595-1400

» Rapid HQ
15 Charron Avenue
Nashua, NH 03063



» protolabs.com
877-479-3680

ISO 9001:2015 and AS 9100 D (Machining) Certified | ITAR Registered